

Divisão Aves

Navalhas de
reposição
para Extratoras
de Cloaca



Junior Frigometal[®]



O sucesso alcançado pela Junior Frigometal se deve, basicamente, à atenção individual que dá a cada cliente. Todo o profissional envolvido no mercado de reposição precisa ter em mente que o seu empenho é a garantia da pontualidade e da qualidade que vão assegurar que a linha de produção atendida esteja sempre pronta para operar.

Esta consciência faz com que a Junior desenvolva sempre novas formas de atuar com mais rapidez e eficiência. O lançamento da linha Pronto! é um exemplo. Uma série de itens de reposição com entregas a curto prazo recebe prioridade na expedição. Um novo processo comercial permite a compra programada, inclusive com entregas agendadas para períodos semestrais ou anuais.

Neste catálogo estão os códigos solicitados com mais frequência. Além destes itens, a Junior dispõe de um departamento específico para a confecção de qualquer peça de reposição, mesmo em formatos, materiais e tratamentos especiais.

Para maiores informações e orçamentos, consulte o nosso setor de vendas: vendas@metaljunior.com.br ou ligue 49 3551 2600





Navalhas extratoras
de cloaca, para máquinas
automáticas e
manuais.



Aço especial e
tratamento térmico.
Fio extradurável.

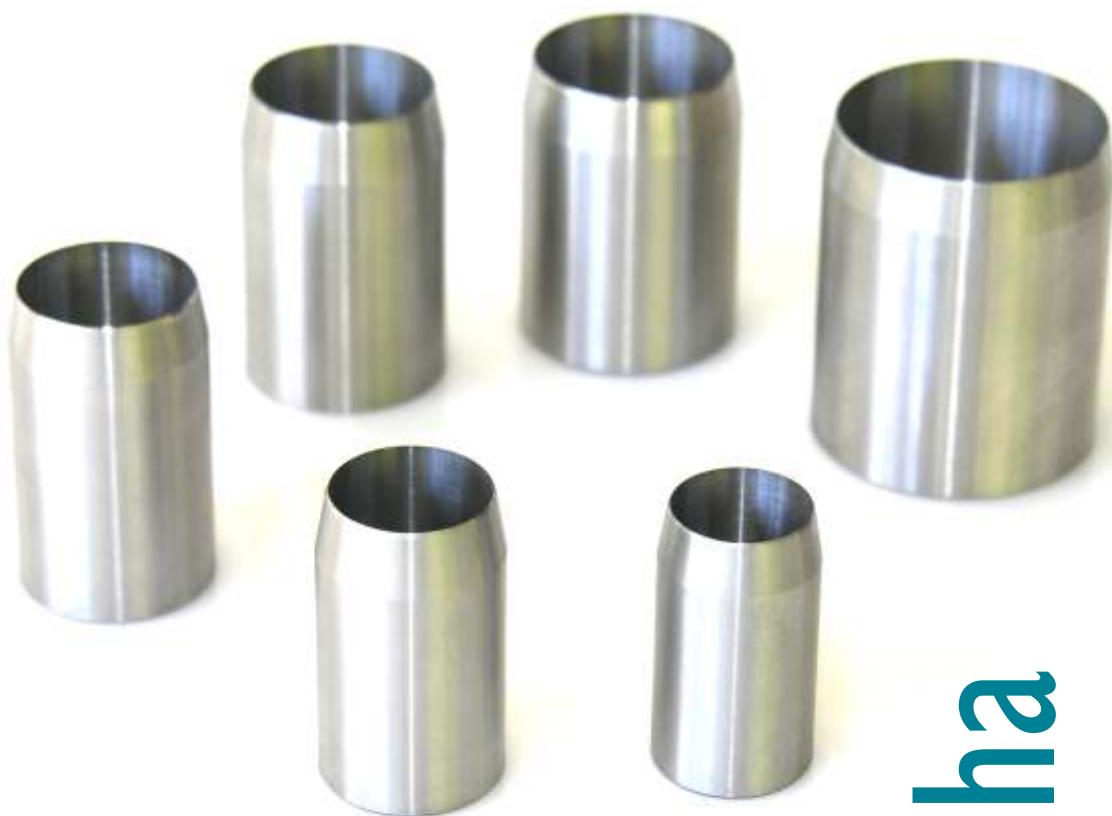

Linha JA

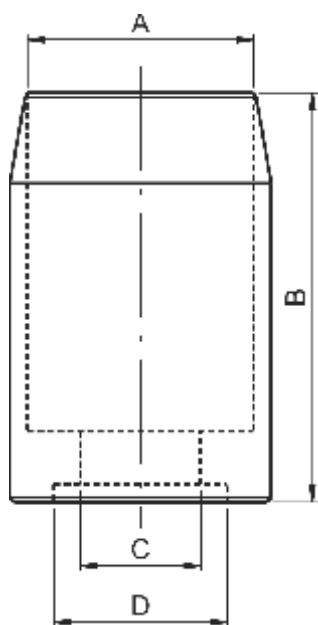

Código JR	Diametro A	Comprimento B	Diametro C	Diametro D
10584	Ø 15.87	38.1	Ø 13.5	Ø 17.5
05808	Ø 19.05	46.03	Ø 13.5	Ø 19.05
01514	Ø 22.22	46.03	Ø 13.5	Ø 19.05
01617	Ø 25.4	42.8	Ø 13.5	Ø 19.05
01516	Ø 25.4	50.8	Ø 13.5	Ø 19.05
01524	Ø 28.1	50.8	Ø 13.5	Ø 19.05
04028	Ø 31.75	50.8	Ø 13.5	Ø 19.05
01517	Ø 34.92	55.56	Ø 13.5	Ø 19.05
01528	Ø 38.1	55.56	Ø 13.5	Ø 19.05
01531	Ø 41.27	55.56	Ø 13.5	Ø 19.05
09137	Ø 44.45	55.56	Ø 13.5	Ø 19.05
07007	Ø 50.8	55.56	Ø 13.5	Ø 19.05

 Aço Inox
  Tratamento Térmico



Modelo I

Linha LI

Linha LI **13793** Navalha $\varnothing 20 \times 97$ CW
 I Aço Inox T Tratamento Térmico

Linha LI **13794** Navalha $\varnothing 20 \times 97$ CCW
 I Aço Inox T Tratamento Térmico

Linha LI **01999** Navalha $\varnothing 24 \times 97$ CW
 I Aço Inox T Tratamento Térmico

Linha LI **13795** Navalha $\varnothing 24 \times 97$ CCW
 I Aço Inox T Tratamento Térmico

Linha LI 01258 Navalha $\varnothing 26 \times 97$ CW
 Aço Inox Tratamento Térmico

Linha LI 13796 Navalha $\varnothing 26 \times 97$ CCW
 Aço Inox Tratamento Térmico



Modelo 2

Linha LI

Linha LI 13797 Navalha $\varnothing 20 \times 87$ CW
 Aço Inox Tratamento Térmico

Linha LI 13798 Navalha $\varnothing 20 \times 87$ CCW
 Aço Inox Tratamento Térmico



Modelo 2

Linha LI

Linha LI 02103 Navalha Ø24 x 87 CW

ⓘ Aço Inox
 Ⓢ Tratamento Térmico

Linha LI 02105 Navalha Ø24 x 87 CCW

ⓘ Aço Inox
 Ⓢ Tratamento Térmico

Linha LI 09209 Navalha Ø26 x 87 CW

ⓘ Aço Inox
 Ⓢ Tratamento Térmico

Linha LI 13799 Navalha Ø26 x 87 CCW

ⓘ Aço Inox
 Ⓢ Tratamento Térmico



Modelo 3

Linha LI

Linha LI 10780 Navalha $\varnothing 22 \times 64$
 I Aço Inox T Tratamento Térmico

Linha LI 09207 Navalha $\varnothing 25 \times 64$
 I Aço Inox T Tratamento Térmico

Linha LI 13800 Navalha $\varnothing 27 \times 64$
 I Aço Inox T Tratamento Térmico

Linha LI 13801 Navalha $\varnothing 30 \times 64$
 I Aço Inox T Tratamento Térmico

Linha ME

Modelo I

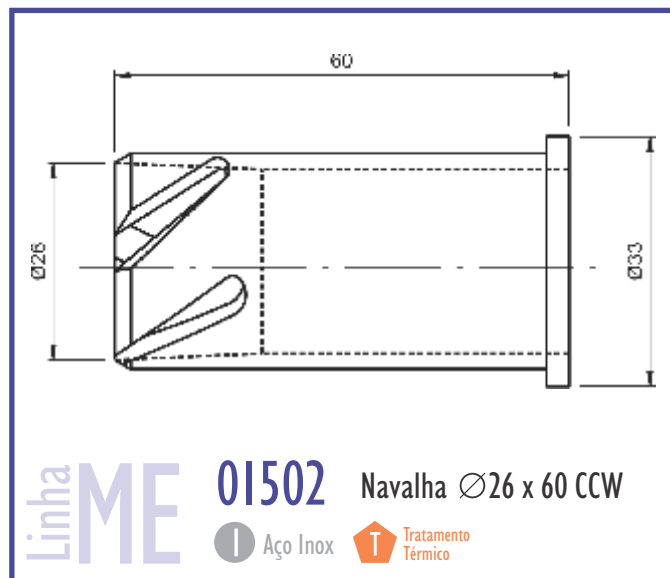
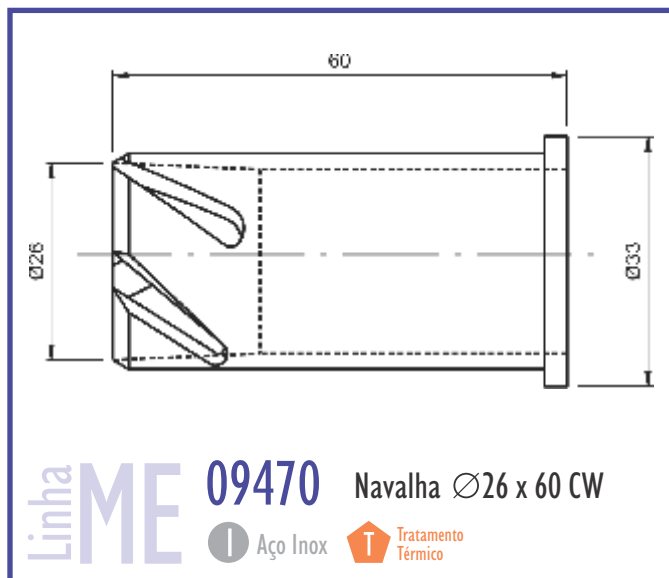
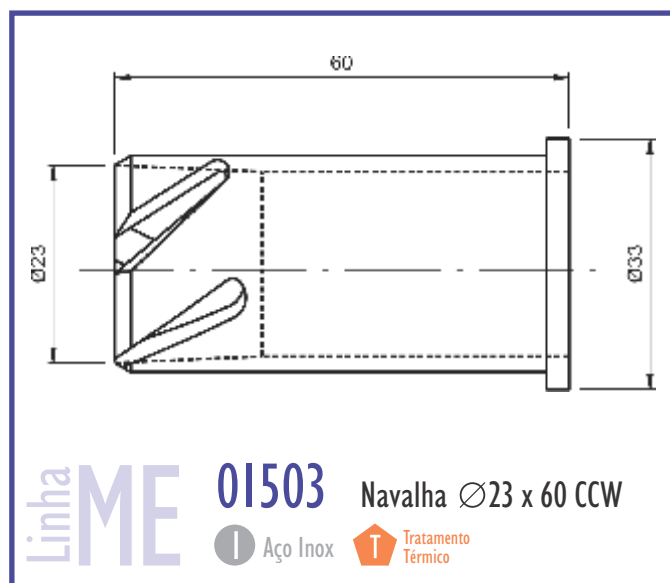
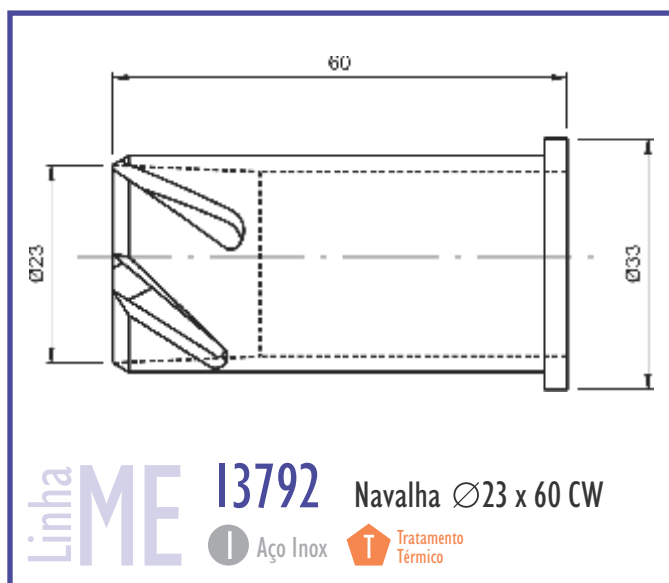



Modelo I

Linha ST

Linha ST 00936 Navalha $\varnothing 25 \times 80$ CW
 I Aço Inox T Tratamento Térmico

Linha ST 01621 Navalha $\varnothing 25 \times 80$ CW
 com rasgo
 I Aço Inox T Tratamento Térmico

Linha ST 00938 Navalha $\varnothing 25 \times 80$ CCW
 I Aço Inox T Tratamento Térmico

Linha ST 13802 Navalha $\varnothing 25 \times 80$ CCW
 com rasgo
 I Aço Inox T Tratamento Térmico



Modelo I

Linha ST

Linha ST I3803 Navalha $\varnothing 28 \times 84$ CW
I Aço Inox T Tratamento Térmico

Linha ST 00941 Navalha $\varnothing 28 \times 84$ CW com rasgo
I Aço Inox T Tratamento Térmico

Linha ST I3804 Navalha $\varnothing 28 \times 84$ CCW
I Aço Inox T Tratamento Térmico

Linha ST I3805 Navalha $\varnothing 28 \times 84$ CCW com rasgo
I Aço Inox T Tratamento Térmico



Modelo 2

Linha ST

66.5
 $\varnothing 25$
 N°18 x 1.5

Linha ST 13806 Navalha $\varnothing 25 \times 66.5$ CW
 I Aço Inox T Tratamento Térmico

66.5
 $\varnothing 25$
 N°16 x 1.5 Esquerda

Linha ST 01450 Navalha $\varnothing 25 \times 66.5$ CCW
 I Aço Inox T Tratamento Térmico

66.5
 $\varnothing 28$
 N°18 x 1.5

Linha ST 13807 Navalha $\varnothing 28 \times 66.5$ CW
 I Aço Inox T Tratamento Térmico

66.5
 $\varnothing 28$
 N°16 x 1.5 Esquerda

Linha ST 13808 Navalha $\varnothing 28 \times 66.5$ CCW
 I Aço Inox T Tratamento Térmico



Modelo 3

Linha ST

Linha ST 12379 Navalha $\varnothing 25 \times 65$ CW
 I Aço Inox T Tratamento Térmico

Linha ST 05062 Navalha $\varnothing 25 \times 65$ CCW
 I Aço Inox T Tratamento Térmico

Linha ST 10954 Navalha $\varnothing 28 \times 65$ CW
 I Aço Inox T Tratamento Térmico

Linha ST 13809 Navalha $\varnothing 28 \times 65$ CCW
 I Aço Inox T Tratamento Térmico



Modelo 3

Linha ST

Linha ST 13810 Navalha $\varnothing 31 \times 65$ CW
 I Aço Inox T Tratamento Térmico

Linha ST 13812 Navalha $\varnothing 31 \times 65$ CCW
 I Aço Inox T Tratamento Térmico

Linha ST 09452 Navalha $\varnothing 34 \times 65$ CW
 I Aço Inox T Tratamento Térmico

Linha ST 13813 Navalha $\varnothing 34 \times 65$ CCW
 I Aço Inox T Tratamento Térmico



Modelo I



Linha SY

Linha SY 01465 Navalha $\varnothing 24 \times 55$ CW
 I Aço Inox T Tratamento Térmico

Linha SY 03915 Navalha $\varnothing 24 \times 55$ CCW
 I Aço Inox T Tratamento Térmico

Linha SY 13814 Navalha $\varnothing 27 \times 55$ CW
 I Aço Inox T Tratamento Térmico

Linha SY 13826 Navalha $\varnothing 27 \times 55$ CCW
 I Aço Inox T Tratamento Térmico

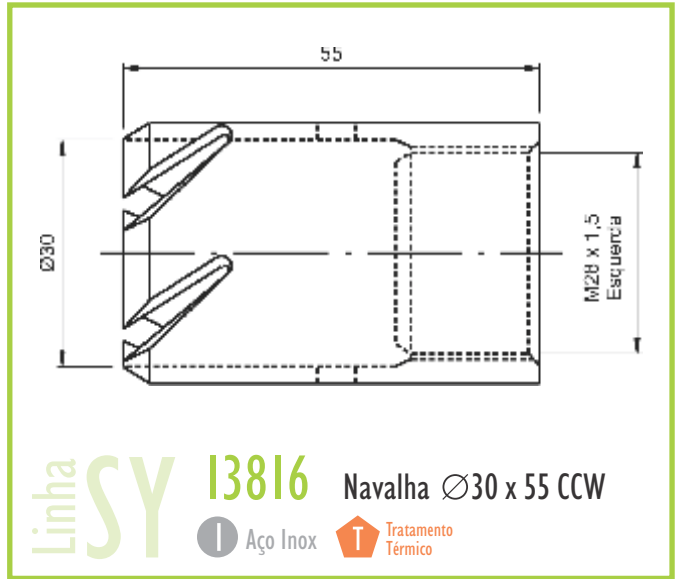
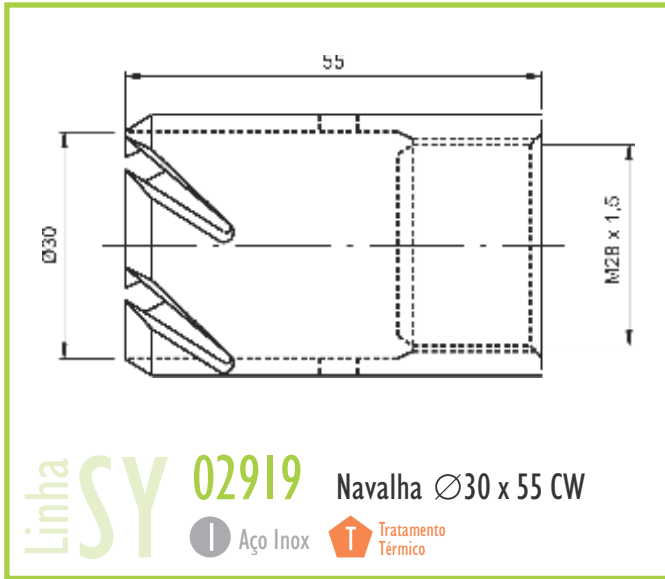

Modelo 2

Linha SY

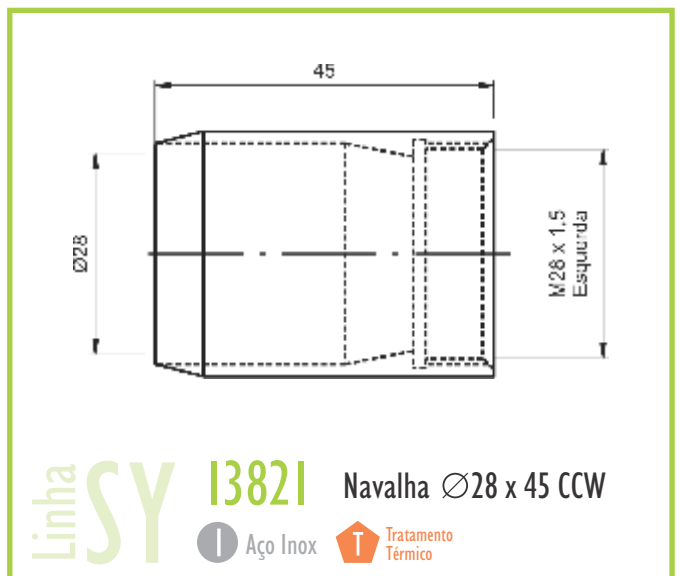
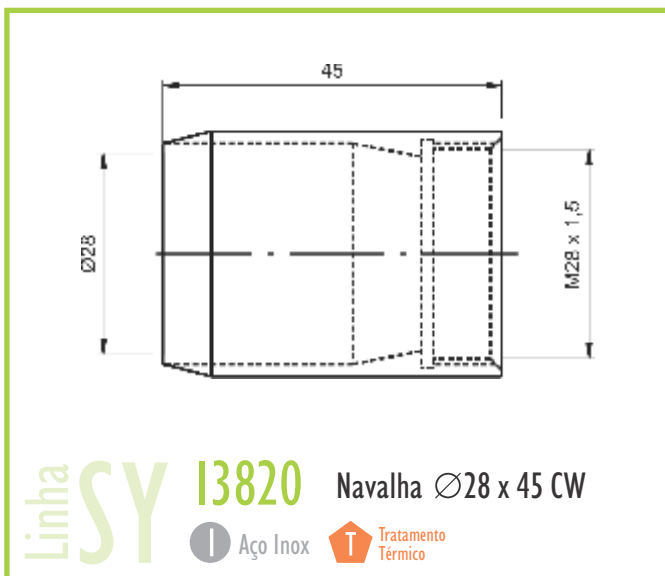



Modelo 2



Linha SY

Linha SY 09497 Navalha Ø25 x 45 CW
 I Aço Inox T Tratamento Térmico

Linha SY 09978 Navalha Ø25 x 45 CCW
 I Aço Inox T Tratamento Térmico

Linha SY 01486 Navalha Ø26.5 x 45 CW
 I Aço Inox T Tratamento Térmico

Linha SY 13819 Navalha Ø26.5 x 45 CCW
 I Aço Inox T Tratamento Térmico

**LINHA
Pronto!**

Entrega
de curto prazo

mancais
e buchas

cortadores de
vísceras

engrenagens

discos de corte



roletes de limpeza (moela e coração)



As navalhas extratoras de cloaca fazem parte da Divisão Aves. Esta é mais uma linha que a Junior Frigometal está disponibilizando em seu catálogo de reposição, agora listadas como peças com entrega de curto prazo, o que significa mais agilidade e confiabilidade.

Para as programações de fornecimento semestrais ou anuais a linha Pronto! pode ter entregas inclusive com datas agendadas. Toda esta facilidade é uma extensão da qualidade Junior. Em breve, outras novidades para que sua empresa esteja sempre bem atendida.

**Fabricadas em qualquer bitola e comprimento,
com engate rápido ou rosqueável.**

**Grande variedade de
modelos a pronta entrega.**

**Formatos especiais
sob encomenda.**



idéias e soluções para a pujante agro-indústria brasileira

49 3551 2600

www.juniorfrigometal.com.br/pronto

Peças integrantes
deste catálogo
de produtos



Linha JA pg 4



Linha LI pg 5



Linha ME pg 9



Linha ST pg 10



Linha SY pg 15

Legenda para
Materiais e
Tratamentos



Tratamento
Térmico



Alumínio



Ferro Fundido



Aço Carbono



Aço Liga



Tratamento
Superficial



Bronze



Polímeros









Aço Ferramenta



Aço Inox

Além da linha de Navalhas, a Junior dispõe de uma de série itens adicionais:

-  Peças de reposição originais para diversas marcas
-  Peças de reposição alternativas para máquinas importadas
-  Peças especiais sob encomenda
-  Placas formadoras
-  Serviços de retífica e recuperação de conjuntos CMS
-  Desossador Automático - Uma máquina revolucionária para a obtenção de carne mecanicamente separada

Consulte o nosso departamento de vendas e descubra as vantagens de contar com um fornecedor com tradição e tecnologia, que é referência em qualidade no setor.



Rua Amadeu Bordin ,338 89600-000 Joaçaba SC - vendas @metaljunior.com.br

49 3551 2600

www.juniorfrigometal.com.br